



TRAILER MANUAL

MODEL CDT1.55 CABLE DRUM TRAILER

WELCOME TO YOUR NEW CDT 1.55 CABLE DRUM TRAILER

This trailer is suitable for the loading and transportation of circular drums/cable reels with maximum sizes and weights as described below
Once on site, a further function of the unit is to assist in the reeling/unreeling of the payload i.e. power cable, telecoms cable, hose or pipe.

Trailer specification

Gross weight	-	2000 kgs
Capacity at full drum width	-	1550 kgs
Drum diameter max	-	2150 mm
Drum diameter min	-	750 mm
Drum width	-	1400 mm
Trailer width	-	2300 mm
Tyre size	-	195 x 14
Towing speed (max)	-	100 kmh

It is very important that a few basic checks are carried out on receipt of your new trailer and also whilst it is in service

Wheel nut tension (79 Nm)
Tyre pressures (66 psi)
Braking system
Electrical system
General condition

It is the driver's responsibility to ensure the vehicle is capable of towing the trailer and that the trailer it is in road worthy condition. (See pre use check list page CDT 1.55 -3)

Operating instructions

Safety

Ensure only trained personnel operate the trailer
Ensure that the safety of yourself and others is observed at all times.

Loading a cable drum

1. Remove the 'R' clips from spindle retaining angles and then remove from the trailer (ref CDT1.55-6)
2. Remove spindle bar from trailer, place it through the cable drum ensuring it is central to the spindle and then lock in position with spindle collars provided
3. Using the correct manual handling techniques manoeuvre the trailer around drum or push the drum into the trailer
4. It may be necessary to pump up the slides to allow spindle bar to locate into the correct position
5. When spindle is located into slides apply the park brake
6. Replace retaining angles and clips
7. Lower and secure rear prop stands
8. Close hydraulic release valve on hand pump (ref CDT1.55-7)
9. Pump handle up and down to lift cable drum into travelling position
10. It may be necessary to adjust the hydraulic control valve located behind hand pump to maintain a level lift (ref CDT1.55-7)
11. Once slides are at maximum lift rotate locking plates through 90 deg (ref CDT1.55-6)
12. Release hydraulic pressure by opening the hydraulic release valve to engage the mechanical locks, once engaged close the hydraulic release valve thus creating a secondary lock. Always ensure the locks are located in the slotted seat.
13. Lift and secure prop stands
14. Hitch trailer to towing vehicle
15. Connect brake away cable
16. Connect and test electrics

Unloading a cable drum

1. Lower and secure prop stands
2. Pump handle up and down to lift slides and release the mechanical locks
3. Once slides are at maximum lift rotate locking plates through 90 deg
4. Release hydraulic pressure to allow the drum to descend
5. It may be necessary to adjust hydraulic control valve located behind hand pump to maintain a level descent
6. Once cable drum is on the ground remove clip from spindle retaining angle and then lift off the retaining angle
7. Using the correct manual handling techniques manoeuvre the trailer from around drum
8. Replace retaining angle and clips
9. lift and secure prop stands

Trailer Pre Use Check List

It is important to note that it is the responsibility of the driver to ensure that a trailer is road worthy, that the load is safe and is suitable to be towed by a specific prime mover.

Before taking the trailer out on the highway, carry out the following simple checks.

1. Ensure (by checking the vehicle vin plate or handbook) that the prime mover and towbar are capable of towing the gross vehicle weight of the trailer (found on the trailer spec plate).
2. Check the brakes and the auto reverse mechanism are operational.
To do this, apply the park brake and push the trailer back, 1st to the left then to the right. The brakes should apply then re-apply each time you push back.
3. Connect the electrical cable and check all the lighting functions.
4. Check breakaway cable is fitted and attached to an appropriate anchoring point on the prime mover.
5. Check tyre tread, tyre pressure (66 psi) and general wheel/tyre condition.
6. Check wheel nut torque weekly (79 Nm).
7. Check condition of drum spindle and ensure locking collars are fitted.
8. Check condition of spindle retaining angles and ensure all securing 'R' clips are fitted.
9. Ensure the drum frames are raised and locked in position and lock plates are seated in slotted seat.
10. Carry out a visual inspection for general condition and wear.

Recommended maintenance

On delivery of your new cable drum trailer and during its service life we recommend regular checks are carried out on the following

- a) Visual inspection of general condition
- b) Check brake away cable
- c) Check tyre pressure
- d) Check electrical system (i.e. light bulbs, plug)
- e) Check hydraulic circuit for leaks
- f) Check brake lining adjustment
- g) Remove play from brake system
- h) Check wheel nut torque
- i) Check tow hitch securing bolts
- j) Check suspension rubbers
- k) Check wheel arm adjustment
- l) Grease all points
- m) Wheel bearings
- n) Full service

Daily	Monthly	Yearly

TRAILER VIN NUMBER MUST BE QUOTED WHEN ORDERING SPARES

PARTS LIST	
ITEM	DESCRIPTION
1	SLIDING CHEVRONS
2	BRAKING SYSTEM
3	ELECTRICAL SYSTEM
4	JOCKEY WHEEL
5	PROP STANDS
6	WHEEL & TYRE
7	HYDRAULIC SYSTEM
8	WHEEL ARM
9	SPINDLE
10	SPINDLE COLLAR

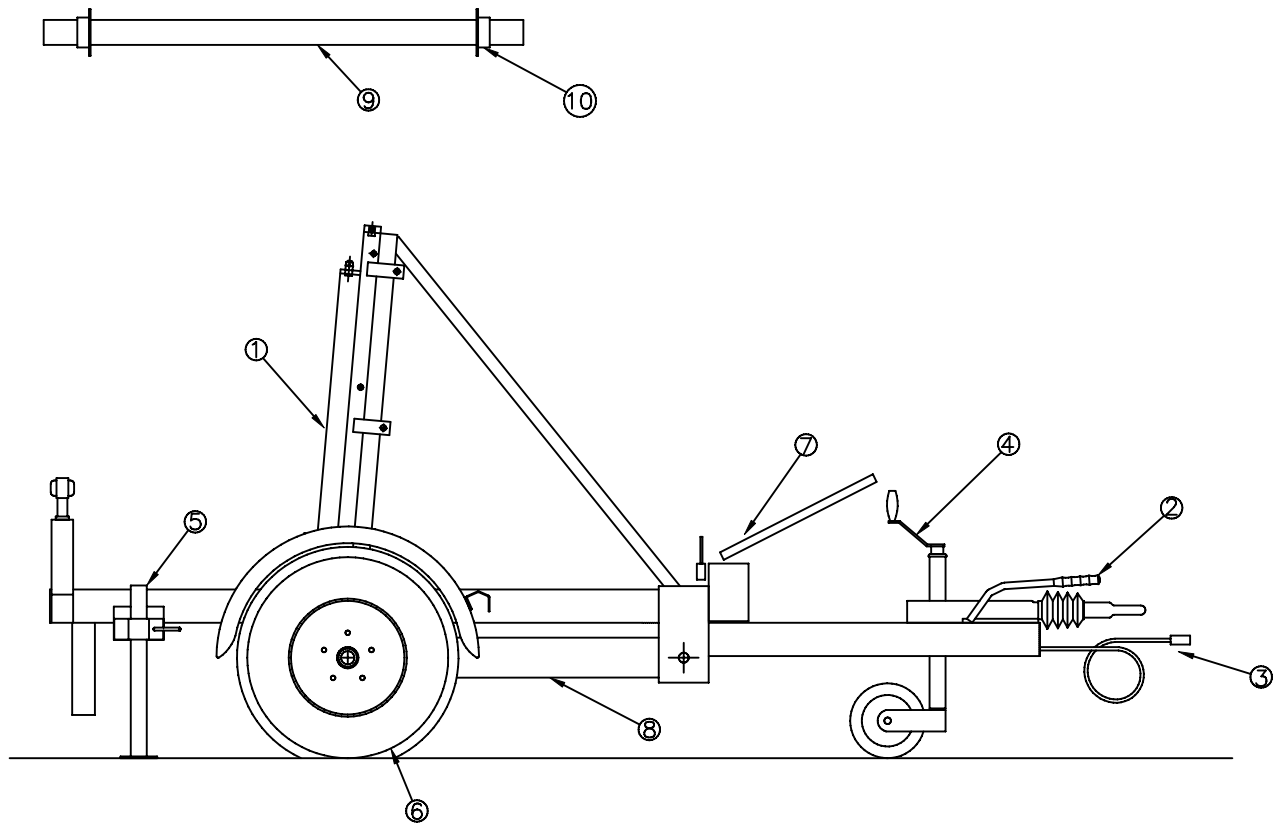

								DATE	17/8/2007	TITLE	GENERAL ARRANGEMENT
								SCALE	N.T.S.		
REF	ISSUE LEVEL	DATE	REF	ISSUE LEVEL	DATE	REF	ISSUE LEVEL	NAME	S.LAWSON	DRG No.	CDT 1.55 - 5

TRAILER VIN NUMBER MUST BE QUOTED WHEN ORDERING SPARES

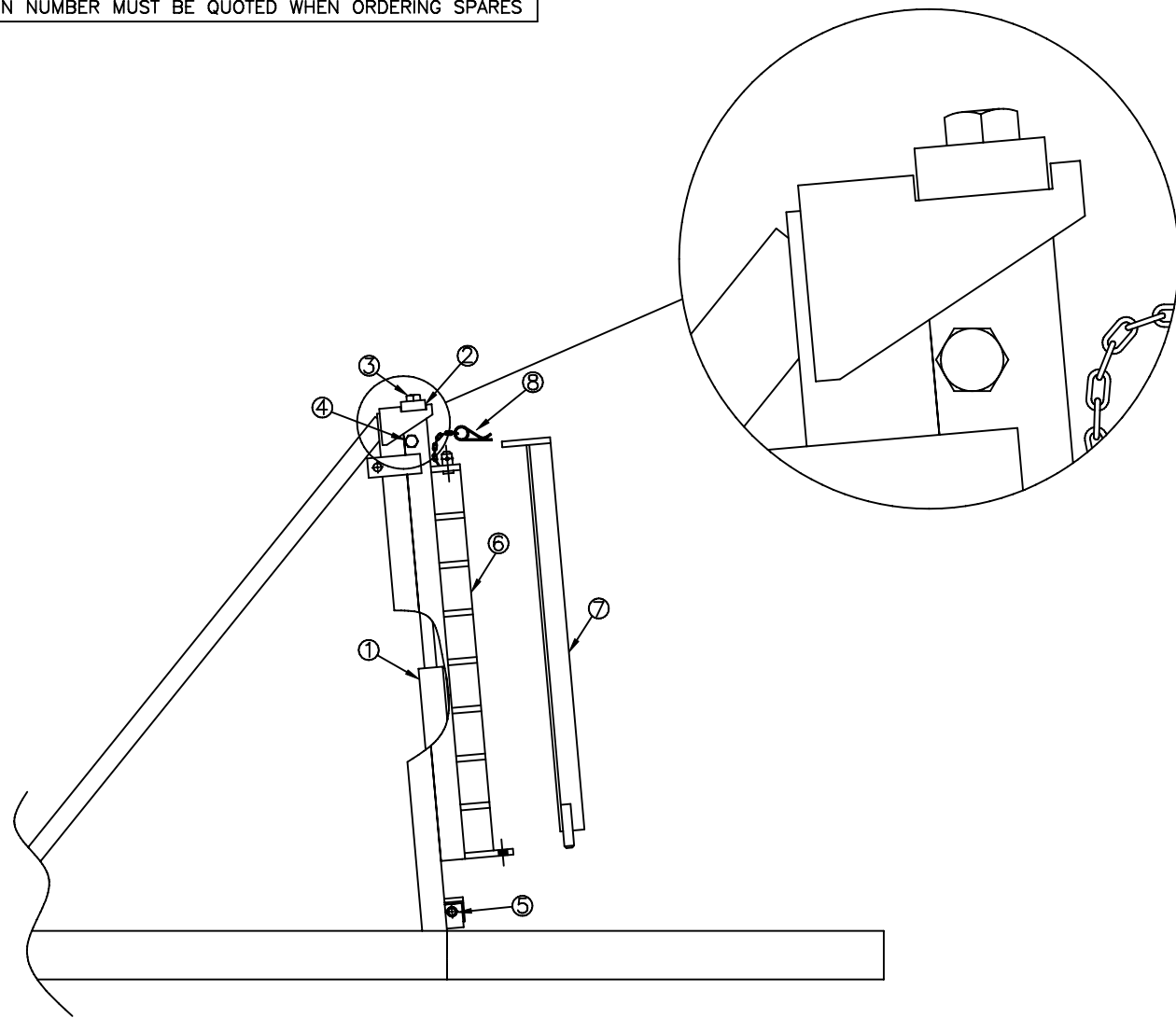

PARTS LIST	
ITEM	DESCRIPTION
1	HYDRAULIC RAM
2	MECHANICAL LOCK
3	MECHANICAL LOCK BOLT
4	HYDRAULIC RAM TOP BOLT
5	HYDRAULIC RAM BOTTOM BOLT
6	SLIDE
7	SPINDLE RETAINING ANGLE
8	RETAINING 'R' CLIP
9	SLIDE RETAILING BOLT

								DATE	17/8/2007	TITLE	LIFT FRAME DETAIL
								SCALE	N.T.S.		
REF	ISSUE LEVEL	DATE	REF	ISSUE LEVEL	DATE	REF	ISSUE LEVEL	DATE	NAME	S.LAWSON	DRG No. CDT 1.55 - 6

TRAILER VIN NUMBER MUST BE QUOTED WHEN ORDERING SPARES

PARTS LIST	
ITEM	DESCRIPTION
1	HYDRAULIC RAM
2	PUMP
3	RELEASE VALVE
4	PUMP HANDLE
5	HYDRAULIC CONTROL VALVE
6	PUMP TO VALVE HOSE
7	NEARSIDE RAM HOSE
8	OFFSIDE RAM HOSE

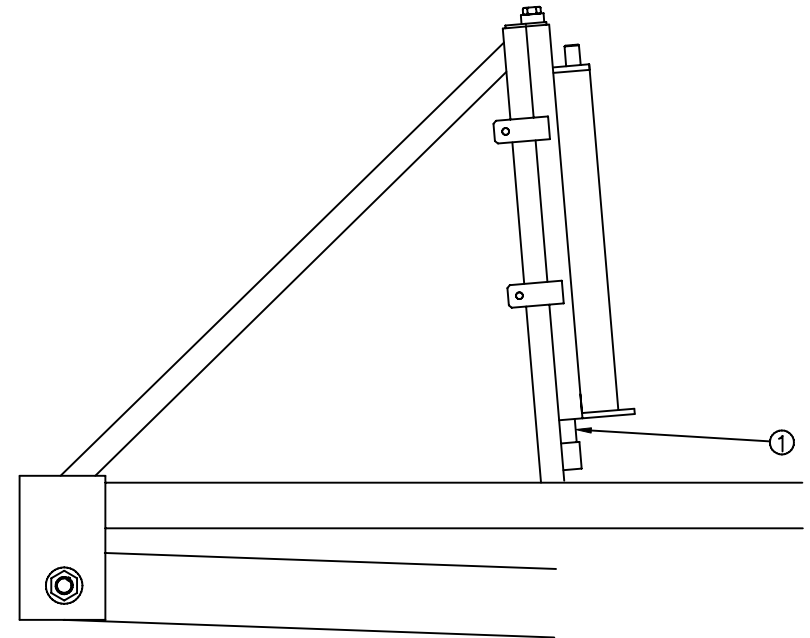
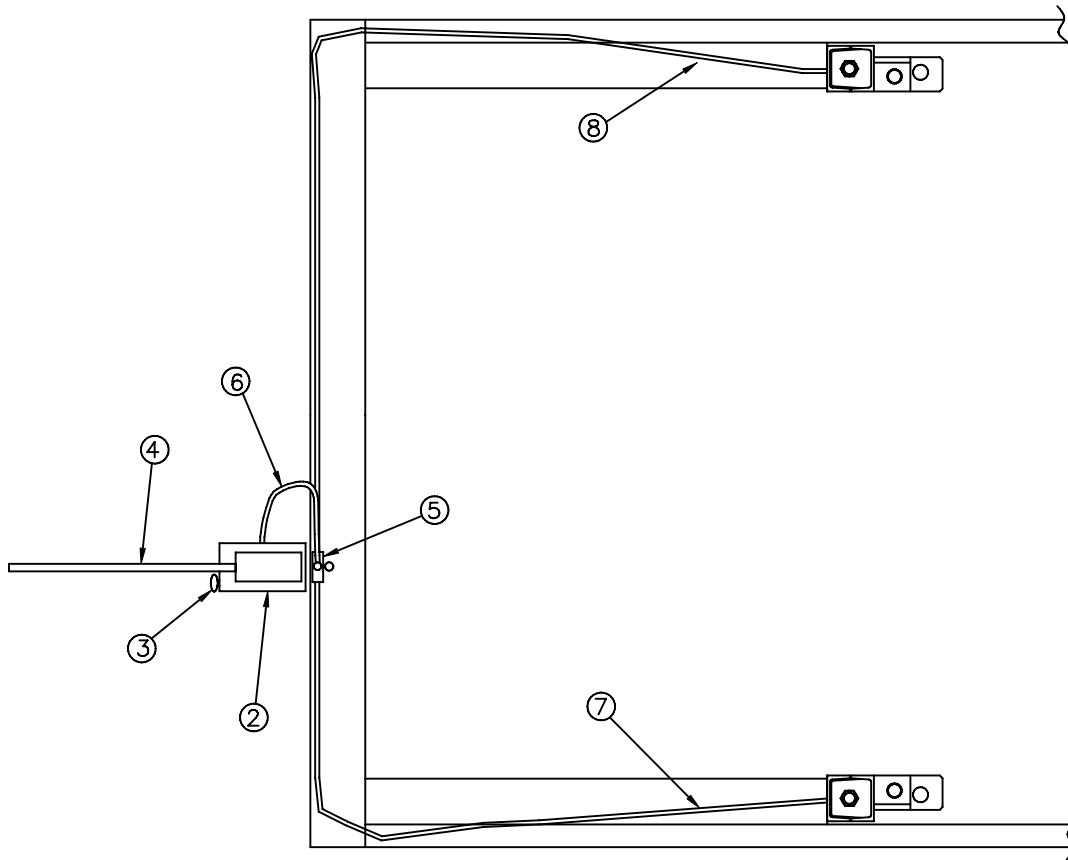

								DATE	19/8/2007	TITLE	HYDRAULIC SYSTEM
								SCALE	N.T.S.		
REF	ISSUE LEVEL	DATE	REF	ISSUE LEVEL	DATE	REF	ISSUE LEVEL	DATE	NAME	S.LAWSON	DRG No. CDT 1.55 - 7

TRAILER VIN NUMBER MUST BE QUOTED WHEN ORDERING SPARE PARTS

PARTS LIST	
ITEM	DESCRIPTION
1	PISTON SEAL
2	GLAND SEAL
3	WIPER SEAL

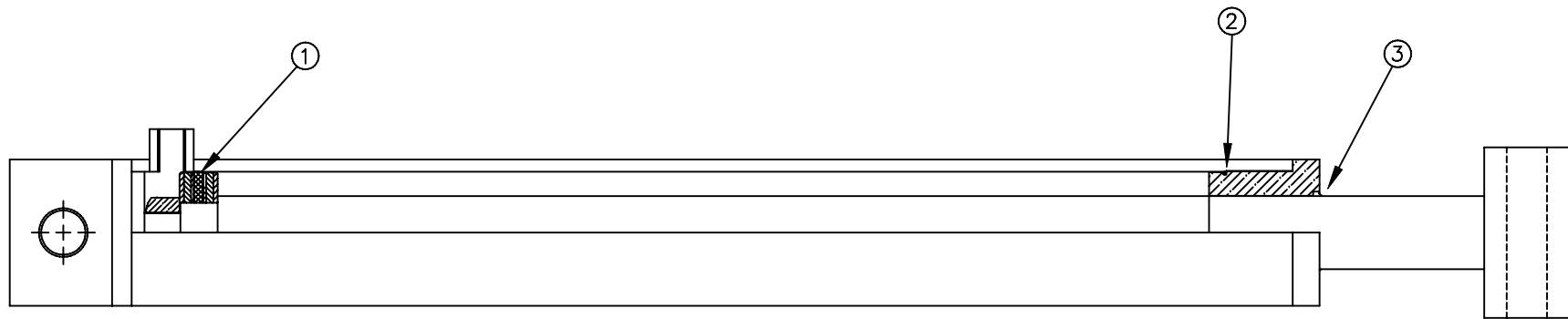

								DATE	11/6/2007	TITLE	HYDRAULIC RAM DETAIL
								SCALE	1=3		
REF	ISSUE LEVEL	DATE	REF	ISSUE LEVEL	DATE	REF	ISSUE LEVEL	DATE	NAME	S.LAWSON	DRG No. CDT 1.55 - 8

TRAILER VIN NUMBER MUST BE QUOTED WHEN ORDERING SPARES

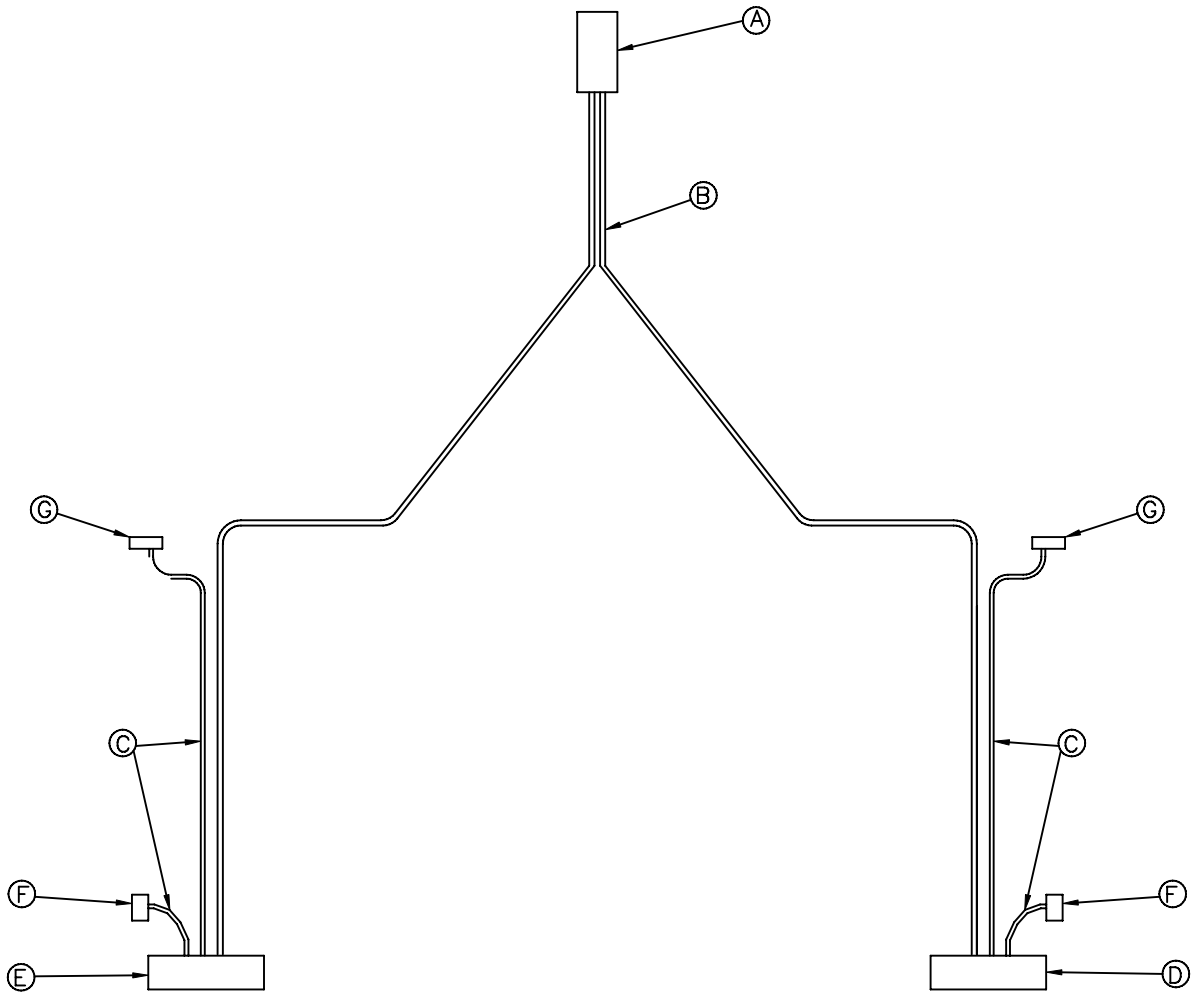

PARTS LIST	
ITEM	DESCRIPTION
A	7 PIN PLUG
B	MAIN LOOM
C	SIDE LIGHT LOOM
D	O/S LIGHT
E	N/S LIGHT
F	OUTLINE MARKER LIGHT
G	FRONT MARKER LIGHT

PLUG KEY		
1	YELLOW	- N/S INDICATOR
2	BLUE	- FOG
3	WHITE	- EARTH
4	GREEN	- OFFSIDE INDICATOR
5	BROWN	- O/S TAIL
6	RED	- STOP
7	BLACK	- N/S TAIL

								DATE	19/8/2007	TITLE	ELECTRICAL SYSTEM
								SCALE	N.T.S.		
REF	ISSUE LEVEL	DATE	REF	ISSUE LEVEL	DATE	REF	ISSUE LEVEL	DATE	NAME	S.LAWSON	DRG No. CDT 1.55 - 9

TRAILER VIN NUMBER MUST BE QUOTED WHEN ORDERING SPARES

PARTS LIST	
ITEM	DESCRIPTION
1	HUB & BRAKE ASSY
2	RUBBER SUSPENSION
3	PIVOT PIN
4	PIVOT BUSH (OILITE)
5	PIVOT BOSS
6	WASHER
7	NUT
8	GRUB SCREW

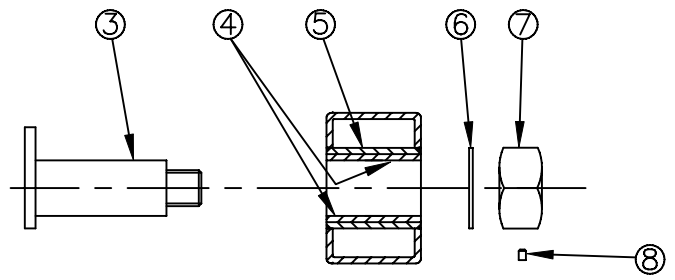
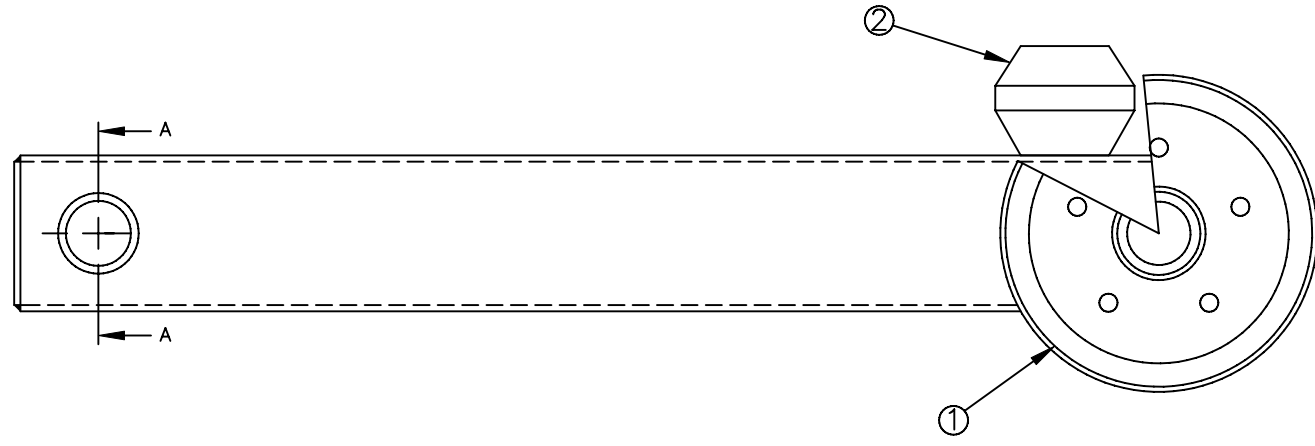

SECTION 'A'-'A'

								DATE	17/8/2007	TITLE	WHEEL ARM DETAIL
								SCALE	N.T.S.		
REF	ISSUE LEVEL	DATE	REF	ISSUE LEVEL	DATE	REF	ISSUE LEVEL	NAME	S.LAWSON	DRG No.	CDT 1.55 - 10

TRAILER VIN NUMBER MUST BE QUOTED WHEN ORDERING SPARES

PARTS LIST

ITEM	DESCRIPTION
1	TOW UNIT
2	BALANCE PULLEY AND CLEVIS
3	BRAKE LEVER
4	WIRE ROPE
5	THIMBLE & GRIPS
6	BRAKE PULLEY
7	PULL ROD & CLEVIS
8	HANDBRAKE
9	HUB BRAKE ADJUSTER (17/19mm)
10	CABLE BRAKE ADJUSTER (17mm)

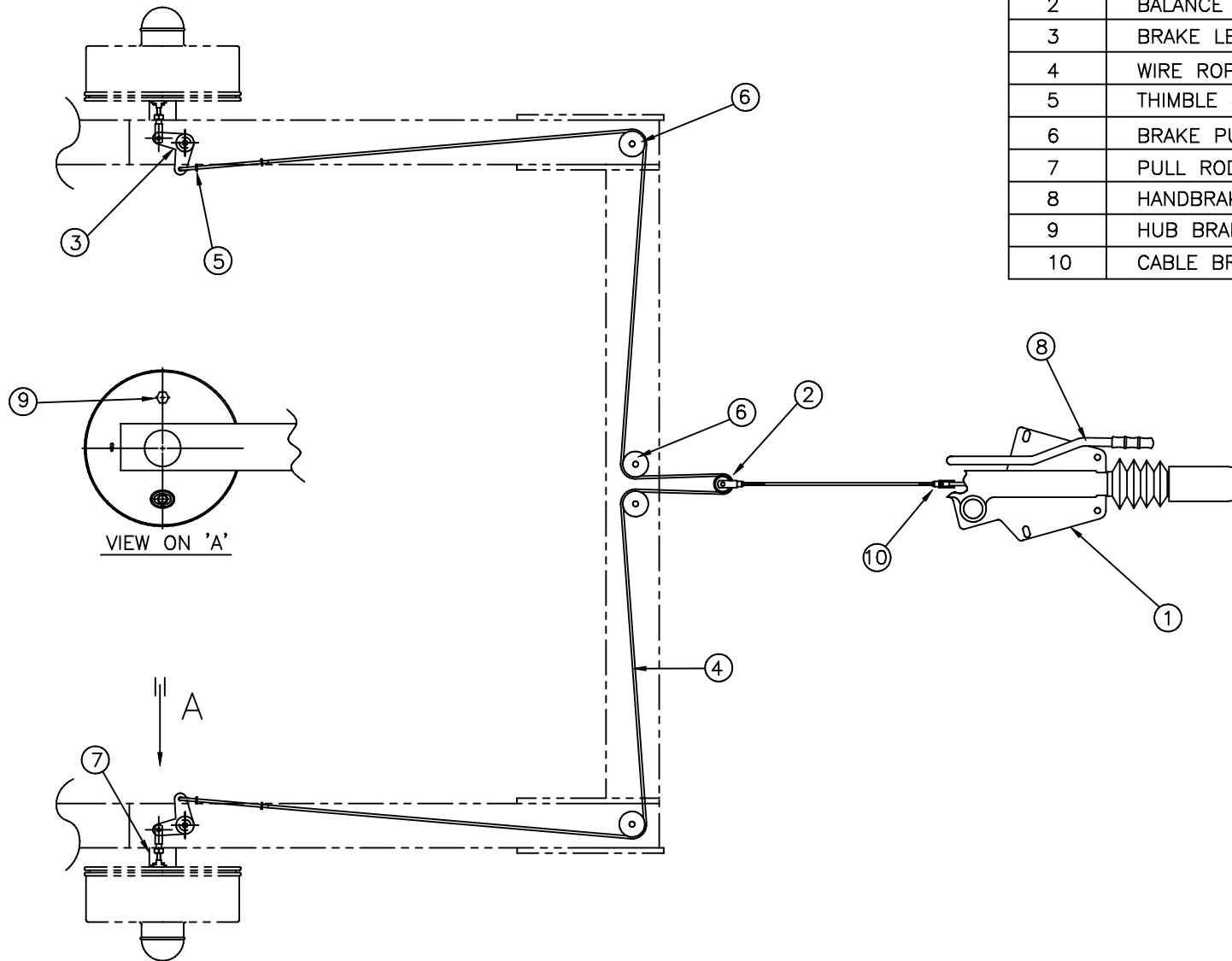

								DATE	17/8/2007	TITLE	OVERUN BRAKE LAYOUT
								SCALE	N.T.S.		
REF	ISSUE LEVEL	DATE	REF	ISSUE LEVEL	DATE	REF	ISSUE LEVEL	NAME	S.LAWSON	DRG No.	CDT 1.55 - 11

TRAILER VIN NUMBER MUST BE QUOTED WHEN ORDERING SPARES

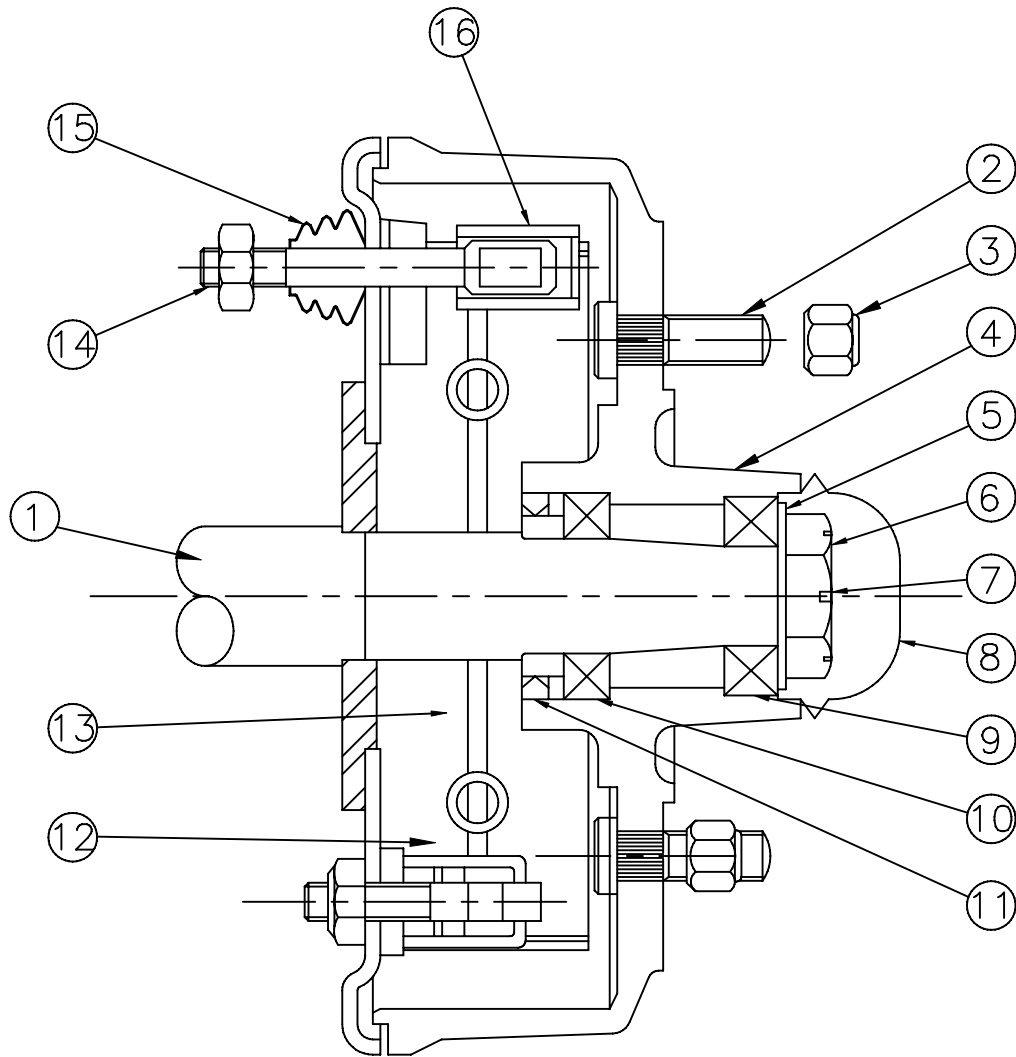

PARTS LIST

ITEM	DESCRIPTION
1	STUB AXLE
2	WHEEL STUD
3	WHEEL NUT
4	HUB / DRUM
5	AXLE WASHER
6	AXLE NUT
7	SPLIT PIN
8	GREASE CAP
9	OUTER BEARING
10	INNER BEARING
11	OIL SEAL
12	BRAKE SHOE
13	SPRING KIT
14	PULL ROD
15	BELLOWS
16	BRAKE EXPANDER

								DATE	17/8/2007	TITLE	HUB DETAIL
								SCALE	N.T.S.		
REF	ISSUE LEVEL	DATE	REF	ISSUE LEVEL	DATE	REF	ISSUE LEVEL	DATE	NAME	S.LAWSON	DRG No. CDT 1.55 - 12

OVERRUN BRAKE SYSTEM ADJUSTMENT

CDT1.55 Cable Drum Trailer

Brake system adjustment to be carried out on level ground with the brakes off. Refer to drawing CDT1.55-11 for system layout

1. Slacken the brake adjuster by loosening the lock nut and turning the brake rod anti clockwise (see drg CDT1.55-11 item 10). This will ensure the brake cables are not pre-loading the hubs.
2. Chock 1 wheel and raise the opposite wheel off the ground stabilise with an axle stand
3. With a 19mm spanner, turn the adjuster (on the brake back plate) clockwise whilst at the same time spinning the wheel in a forward rotation until the wheel locks up. Once locked, back off the adjuster until the wheel will rotate but with slight resistance (i.e. slightly binding)
4. Repeat for the other side.
5. With one wheel still off the ground, adjust the brake rod/cables- this is a 2 man job. Clamp mole grip type pliers onto the brake rod and turn clockwise whilst at the same time spinning the wheel in a forward rotation until the wheel locks up. Once locked, back off the adjuster until the wheel will rotate but with slight resistance. Secure the brake rod by tightening the lock nut
6. The brake system is now correctly adjusted

TO TEST THE SYSTEM

1. Apply and then release the park brake a number of times ensuring the brakes lock and release each time. If the brakes do not lock, recheck the adjustment and or check the lining for wear. If the brake do not release, loosen the brake cable adjustment slightly and recheck.
2. Re-apply the park brake and check the reverse mode by pushing the trailer backwards, first to the right and then to the left, each time the brakes should release and automatically re-apply. If this does not happen, readjust the system.
3. The system is now tested and the trailer ready for use.