



K45 360

Rapid Deployment Mobile Lighting System

Operator's Manual



This manual covers the K45 360 with the following product codes:
SLK45LED | SLK45LED/110V

The information contained in this manual is based on products manufactured up to the time of publication. Ritelite (Systems) Ltd reserves the right to change any of this information without notice.

No part of this manual may be reproduced in any form or by any means, electronic or mechanical without express written permission from Ritelite (Systems) Ltd.

Any type of reproduction or distribution not authorized by Ritelite (Systems) Ltd represents an infringement of valid copyrights, and violators will be prosecuted. We expressly reserve the right to make technical modifications, even without due notice, which aim at improving our products or their safety standards.

IMPORTANT INFORMATION ABOUT YOUR K45 360

Use this page to record important information about your K45 360.

UNIT PRODUCT REFERENCE	
UNIT SERIAL NUMBER	

This information can be found on your K45 360's data plate which is found below the main control panel.

NOTE: Below is an example of the K45 360 data plate.

RITELITE (SYSTEMS) LTD					
PRODUCT	K45 360 PORTABLE LIGHTING TOWER				
PRODUCT CODE	SLK45LED/110V				
SUPPLY VOLTAGE	110V AC 50/60HZ				
OPERATING POWER REQUIREMENT	820W				
IP RATING	IP65	MANUFACTURE DATE	Jan 2024		
HEIGHT (MAX)	4.5m	HEIGHT (MIN)	1.48m	WEIGHT	90Kg
SERIAL NUMBER	0000000	Made in the UK			
Ritelite (Systems) Ltd, Meadow Park, Bourne Road, Essendine, Stamford, Lincolnshire, PE9 4LT, England Tel. +44 (0) 1780 758585 E-mail. sales@ritelite.co.uk Web. www.ritelite.co.uk					

You will be required to supply the products serial number when contacting Ritelite (Systems) Ltd or one of Ritelite's approved dealers about parts and service.

IMPORTANT SAFETY INSTRUCTIONS

Some versions of this product are fitted with a polarized plug (one pin is wider than the other) as a feature to reduce the risk of electric shock. This plug type will fit in a polarized outlet only in the correct orientation. If the plug does not fit fully in the outlet, reverse the plug. If it still does not fit contact a qualified electrician. Never use with an extension cord unless plug can be fully inserted. Do not alter the plug.

CONTENTS

SECTION TITLE	PAGE NUMBER
Section 1: Introduction & Applications for use	4
Section 2 : Safety Rules	5
Section 3: Technical Specifications	10
Section 4: Safety and Operating Labels	11
Section 5: Setting up the K45 360	14
Section 6: Operating Instructions	15
6a) Pre-operation inspection	15
6b) Unit Stability Deployment Process	16
6c) Function Tests	18
6d) Raising and Lowering Mast Process	19
6e) Packing away and Transport	24
Section 7: Maintenance	27

Section 1: INTRODUCTION & APPLICATIONS FOR USE

The K45 360 is designed as a simple to use but powerful portable LED lighting system. It should only be used as a device to provide light as designed and for no other purpose.

All users must read, understand and obey these safety rules and operating instructions before operating the K45 360 lighting system. Only trained operators or competent personnel should operate the K45 360.

This Manual should stay with the K45 360 at all times.

APPLICATIONS FOR USE

The K45 360 mobile lighting system is designed for use in the following applications only. It should not be used for any other purpose. If in any doubt about applications for use please contact either Ritelite (Systems) Ltd or Ritelite (Systems) Ltd's distributor for more information.

- Sports lighting indoor and outside
- Indoor area lighting
- Area lighting for construction site /scene lighting
- Area lighting for events applications
- Maintenance work
- Rescue operations
- Media and Film



WARNING



Failure to follow the instructions and safety rules in this manual may result in death or serious injury.

Section 2: SAFETY RULES

It is important that every user understands and observes the safety rules before setting up or using the K45 360 Lighting System.

The Manufacturer, Ritelite (Systems) Ltd cannot anticipate every possible circumstance that might involve a hazard. The warnings in this manual and on labels affixed to the K45 360 will therefore not cover every eventuality. If using a procedure or operating method not specifically recommended by the manufacturer then the user must verify that it is safe for others and that it does not make the equipment unsafe.

Throughout this manual and on labels on the K45 360, DANGER, WARNING and CAUTION blocks are used to alert personnel to special instructions about a particular operation that may be hazardous if performed incorrectly or carelessly. Observe them carefully. Their definitions are as follows:

 DANGER	 WARNING	 CAUTION
Indicates a hazardous situation which, if not avoided, will result in death or serious injury.	Indicates a hazardous situation which, if not avoided, could result in death or serious injury.	Indicates a hazardous situation which, if not avoided, could result in minor or moderate injury.

These safety alerts cannot eliminate the hazards that they indicate. Common sense and strict compliance with the instructions within this manual are essential to preventing accidents.

WARNING

When using outdoor use portable luminaires, basic safety precautions should always be followed to reduce the risk of fire, electric shock and personal injury including the following:

- a) **Use only three-wire outdoor extension cords that have three-prong grounding plugs and grounding receptacles that accept the appliance's plug.**
- b) **Residual Current Device (RCD) protection is to be provided on the circuits (s) or outlet (s) to be used for the wet location portable luminaire. Receptacles are available having built-in RCD protection and are able to be used for this measure of safety.**
- c) **Use only with a relevant IP rated extension cord for outdoor use.**

GENERAL SAFETY RULES & POTENTIAL HAZARDS WHEN SETTING UP AND USING THE K45 360 LIGHTING SYSTEM

FALL HAZARDS

- Do not stand on any part of the mast or light head brackets.
- Do not cling to or pull on the mast.
- Do not climb on or use any part of the K45 360 as a platform or step.

TIP OVER HAZARDS

- Do not raise the mast until the K45 360 is positioned level on a firm, flat, horizontal surface with all four support legs correctly deployed and locked.
- Do not place the K45 360 on a smooth low friction surface even if firm and level. e.g. snow/ice. The unit could be prone to sliding sideways in these circumstances.
- Do not set up the K45 360 in windy conditions where wind speed and gusts could exceed the wind rating of the product.
- Check area where the product has been set up on a regular basis to ensure stability has not been compromised through changing conditions, e.g. through wind or water logged ground.
- Ensure the leg carriages are locked in position before attempting to raise the mast. Use the leg adjustment knobs to raise / lower the legs.
- Do not release the leg carriage levers when the mast is raised.
- Prior to setting up, check the area for any possible hazardous conditions.
- Do not use blocks to level the K45 360.

- Do not move the K45 360 with a raised load.
- Do not place ladders or scaffolding against any part of the K45 360.
- Do not use the K45 360 on a moving or mobile surface or vehicle.
- Avoid debris and uneven surfaces when rolling a K45 360 with the legs folded up.
- Do not use the K45 360 for any purpose other than that for which it is designed.
- The K45 360 is NOT a lifting device for anything other than the fitted Light heads.

ELECTROCUTION HAZARDS

- Maintain safe distances away from electrical power lines in accordance with applicable governmental regulations.
- Keep away from the K45 360 if it contacts energized power lines. No-one must touch or operate the K45 360 until power lines are shut off.
- When setting a K45 360 up in an area which does have electrical power lines in the vicinity allow enough distance for mast movement and electrical line sway or sag and be aware of strong or gusty winds.
- Ensure product is not being set up in a potentially explosive environment – the K45 360 is not an ATEX approved product.
- Ensure the product will be powered by a RCD protected supply to prevent risk to operators or damage to the K45 360.
- The K45 360 is not designed to be submersed under water.

BODILY INJURY HAZARDS

- The operator should stand well back from the product during operation. Do not touch any part of the product whilst operating.
- It is recommended that the user wears gloves whilst operating or setting up the K45 360.
- In slippery or uneven terrain it is recommended that two people manoeuvre the product at all times.
- The K45 is designed to be simple to deploy and operate by one person however there may be situations where it is recommended that two people manoeuvre the product.
- Do not manoeuvre the K45 360 product for long distances in extreme temperatures.
- Do not switch on light heads until mast is raised.
- Do not stare directly into the lights to prevent damage to eyes.
- Set the K45 360 up so light spill cannot form a nuisance or danger to others, especially those using machinery.
- Where possible the K45 360 should be set up away from personnel or moving vehicles.
- Do not grasp or move the light heads after use until they have cooled down for at least 10 minutes.

Do not place any body part over the top of the K45 before or during deployment. Do not touch mast sections whilst mast is being raised.

CRUSHING HAZARDS

- Ensure the K45 360 is set up on a firm and horizontal flat surface.
- Do not raise the mast until the K45 360 is positioned level on a firm horizontal flat surface with all four support legs correctly deployed and locked.
- Do not stand under or allow personnel under the K45 360 when the mast is raised or lowered.
- Keep hands and fingers away from any potential pinch points.
- Maintain a firm grasp on the leg when unlocking. The leg will drop downwards causing possible risk to operator.
- Never move the K45 360 with the mast partly or fully raised.

COLLISION HAZARDS

- Ensure the area around the product and above the product is clear of any possible obstructions before starting to set the K45 360 up.
- Use common sense and planning when transporting the K45 360 on any incline or slope.
- On slippery or uneven terrain it is recommended that two people manoeuvre the product at all times.
- Do not load for transport unless the K45 360 and vehicle are on a level horizontal surface. Use proper lifting techniques to load the machine to prevent collision into other items on the transport vehicle.

DAMAGED MACHINE HAZARDS

- Do not use a damaged K45 360 or a K45 360 that is not working properly.
- Do not use a K45 360 with a damaged mast.
- Conduct a thorough pre-operation inspection prior to each use.
- Be sure that all labels are in place and legible.
- Do not use if there are any visible damaged parts. Contact your dealer to arrange for spares or repair options.
- Do not use any type of lubrication on the column surfaces.
- Do not attempt to defeat / modify any of the interlocks.

IMPROPER USE HAZARD

- Never leave a K45 360 unattended with the mast raised unless a full risk assessment for the application they are being used for has been undertaken by a competent person. Unauthorized personnel may attempt to operate the K45 360 without proper instruction potentially causing injury to themselves or others.
- Do not place the K45 360 on a smooth low friction surface even if firm and level. e.g. snow/ Ice. The unit could be prone to sliding sideways in these circumstances.
- The K45 360 must only be operated in a vertical position.

- The device is to be used only for its prescribed purpose. Any use other than that mentioned is considered to be a case of misuse.
- The user/operator, and not the manufacturer shall be liable for any damage or injury resulting from such cases of misuse.
- It is imperative to observe the local accident prevention regulations.
- The same applies for the general rules of occupational health and safety.
- The manufacturer is not liable for indirect consequential damage and financial loss.
- The manufacturer shall not be liable for any changes made to the device nor for any damage resulting from such changes.
- The K45 360 is not designed to be towed on a public highway.

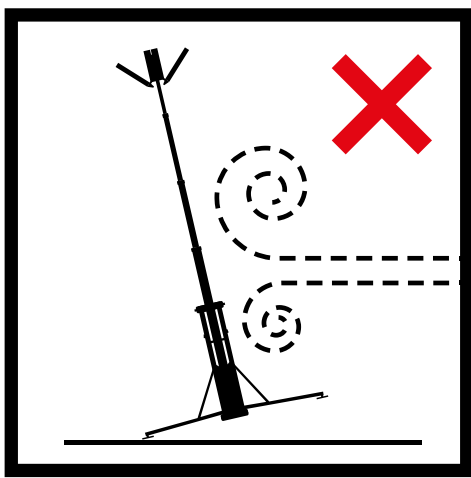
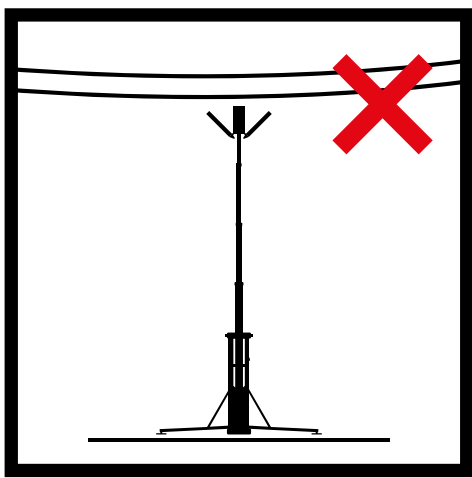
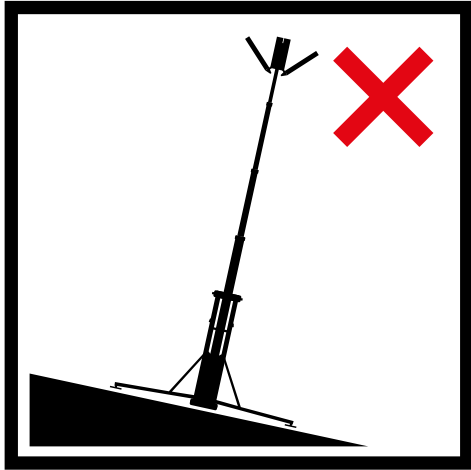
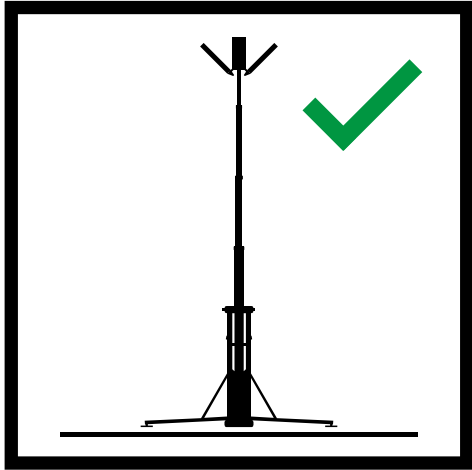

Section 3: TECHNICAL SPECIFICATIONS

PRODUCT CODE	VOLTAGE	MAST HEIGHT	WEIGHT	CLOSED DIMENSIONS	OPEN DIMENSIONS
SLK45LED	240V	4.5m	90Kg	400 x 400 x 1480mm	2430 x 2430 x 4500mm
SLK45LED/110V	110V	4.5m	90Kg	400 x 400 x 1480mm	2430 x 2430 x 4500mm

ELECTRICAL

Input 110V 7A or 240V 3.5A Max AC 50/60Hz 820W

LED LIGHT HEADS

IP65 Integral Electronic Driver 100-240V Input
6500K Daylight White
max 85,000 Lumens per K45 360 (6 x light heads)

Mains input via 110V/240V plug/coupler link through as per customer requirements.

Section 4: SAFETY AND OPERATING LABELS

LABEL POSITIONS

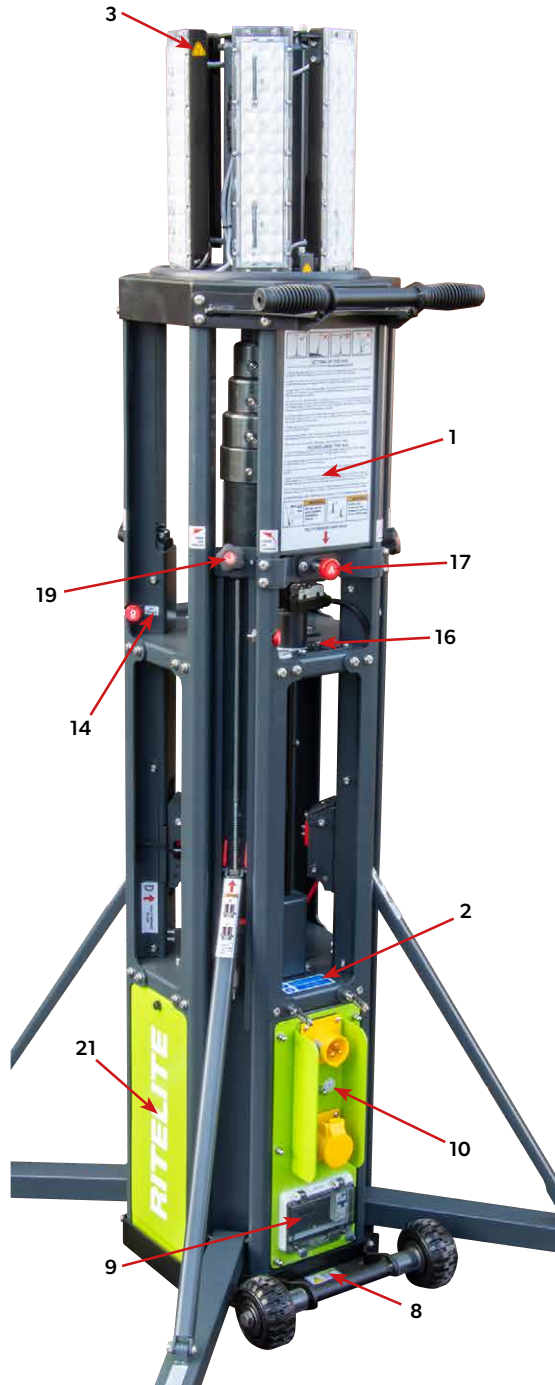
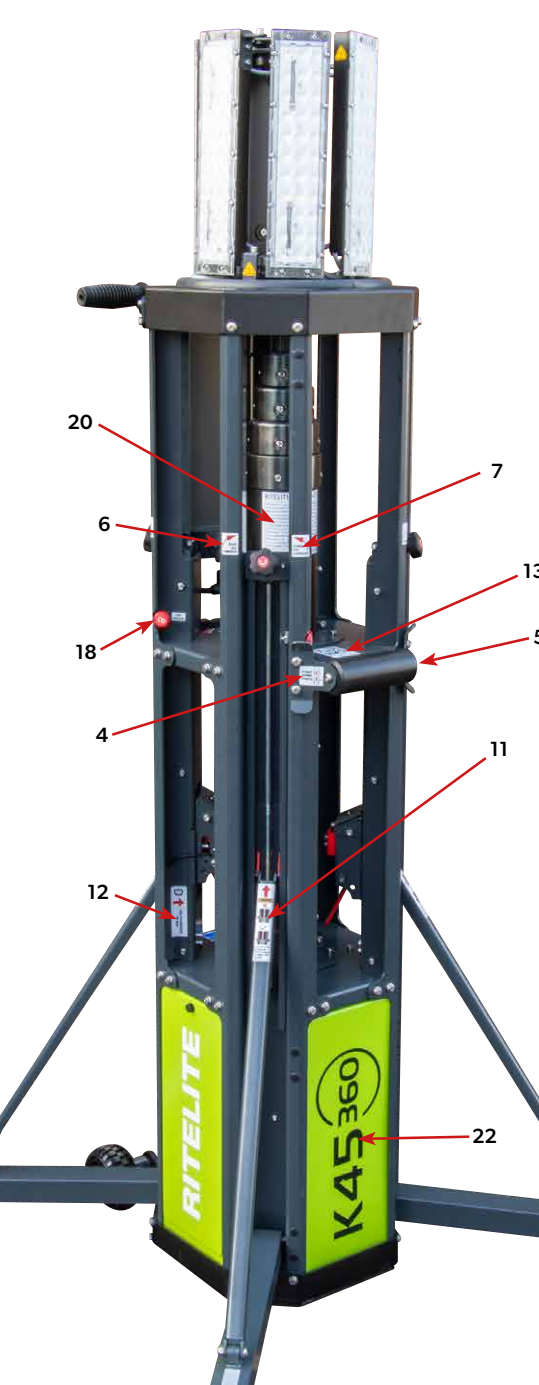

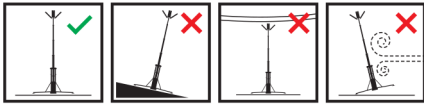

SETTING UP THE K45

1. Push K45 to vertical position onto its base on **firm, horizontal level ground**.
2. Pull out light head transit lock 'A', then pull out all four leg release catches 'B' and lower legs to the ground. Check the brightness dial is turned fully to the left to the 0% position.
3. Connect the power cable and turn on the main power switch. A leg stability LED should illuminate, indicating that the leg is not adjusted correctly to support the product securely.
4. Rotate knobs 'C' to adjust the leg carriage. The leg should click in so it will not raise when pulled upwards. Then adjust the knob until pressure is applied to the ground, the red LED will extinguish when enough pressure is applied.
5. From the control panel side walk in a clockwise motion around the product starting from the level and secure first leg. Continue to secure all legs. Ensure they can't be pulled up and adjust the knobs until enough pressure is applied and the LED's are all extinguished. Pay attention to the bubble level and adjust the legs so the unit is as straight as possible.
6. The 'MAST RAISE' button will illuminate when the legs are all secure and light heads released. Press once to raise the mast until the light heads are above the top of the unit if they aren't already, then briefly press the red stop button.
7. Adjust light heads to the desired positions, they can be rotated from 180° to 360°. Adjust the downward angle as required.
8. Press the 'MAST RAISE' button. The mast will raise to full height then stop. It can be stopped at a lower position by briefly pressing the red stop / lower button. Rotate the brightness to the desired level.

NOTE: Mast stop / lower button - Brief press - stop. Long press - Lower.

PACKING AWAY THE K45

1. Rotate the brightness dial fully to the left to the 0% position. Press the 'MAST STOP / LOWER' button to release the air pressure in the mast. The light heads will lower.
2. When the light heads reach the top of the frame they will be held by the gas strut and stop. Fold the light heads back into their stowed position.
3. Push the light heads down into the transport lock clicks and holds them in position.
4. Rotate the leg knobs clockwise to release the locking mechanism from the leg tie bars. Pull the red leg carriage lever 'D' towards you to release the locking mechanism from the leg carriage. Hold in position and raise leg. Repeat with the other legs. Ensure the legs lock securely into the frame.
5. Turn off the power and disconnect the cable. Grasp the handles and take the K45 360's weight as you lower it gently onto the wheels for transport. If you are in any doubt enlist the help of others.

NO USER SERVICEABLE PARTS. SERVICING TO BE CARRIED OUT BY AUTHORISED PERSONNEL ONLY.

<p>MAX 45 mph</p>	<p>WARNING</p> <p>Do not use in wind speeds exceeding 45mph</p>
<p>PULL TO RELEASE LIGHT HEAD</p>	<p>WARNING</p> <p>Ensure light heads are fully lowered to ground before lifting legs</p>

PULL TO RELEASE LIGHT HEAD

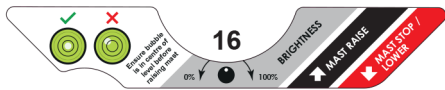

17



18



19



RITELITE

21

K45 360

22

2

To be used by trained and authorised personnel only

Wear Gloves



3

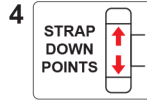

4 STRAP DOWN POINTS



5 STRAP DOWN POINTS



6



7



10

11

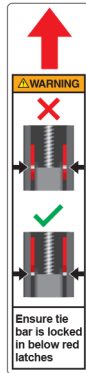

12



D PULL TO RELEASE TIE BAR



14

LEG RELEASE

13



K45 Setup Instructions & Resources

15



TO RESET RCBO PRESS BLUE + WHITE LEVERS FULLY DOWN UNTIL THEY CLICK. TO THEN RESTORE POWER PRESS RED STOP FULLY UPWARDS UNTIL THEY ENGAGE

20

RITELITE (SYSTEMS) LTD

PRODUCT	K45 360 PORTABLE LIGHTING TOWER		
PRODUCT CODE	SLK45LED		
SUPPLY VOLTAGE	240V AC 50/60HZ		
OPERATING POWER REQUIREMENT	820W		
IP RATING	IP65	MANUFACTURE DATE	Jan 2024
HEIGHT (MAX)	4.5m	HEIGHT (MIN)	1.48m
WEIGHT	90Kg		
SERIAL NUMBER	0000023	Made in the UK	

Ritelite (Systems) Ltd, Meadow Park, Bourne Road, Essendine, Stamford, Lincolnshire, PE9 4IT, England
Tel: +44 (0) 1753 758555 | E-mail: sales@ritelite.co.uk | Web: www.ritelite.co.uk

REF.	DESCRIPTION	QUANTITY
1	Instructions for raising and lowering the mast	1
2	Warning to be used by trained personnel / Wear gloves	1
3	Hot warning	9
4	Strap down point	1
5	Strap down point	1
6	Raise leg carriage	4
7	Lower leg carriage	4
8	CAUTION - risk of electric shock	1
9	Leg stability interlock switch (subject to options fitted)	1
10	Earthing point	1
11	Tie bar leg latch warning	4
12	Tie bar release lever	4
13	QR code link label	1
14	Leg release	4
15	RCBO reset instructions (subject to RCBO type fitted)	1
16	Brightness control, bubble level, mast raise and mast lower	1
17	Pull to release light head	1
18	Pull to release legs	4
19	Leg carriage adjustment	4
20	Product data plate including serial number and weight information	1
21	Ritelite *	2
22	K45 360 product label *	1

* These labels are subject to change depending on individual customer configurations.

Section 5: SETTING UP THE K45 360

Inspect the proposed area for use.

An inspection of the proposed area in which to set up the K45 360 is necessary to ensure it is suitable for safe operation. This inspection should be performed by the operator prior to moving the K45 360 into position.

The area should be firm, horizontal, level and free from obstructions.

WARNING

Operators should be aware of the following possible hazardous situations. The operator should also remember these hazards, watch and avoid them while moving, setting up and operating the K45 360.

- **Uneven terrain, drop-offs or holes**
- **Bumps and floor obstructions**
- **Debris either on proposed site or on route to site**
- **Overhead obstructions and high voltage conductors**
- **Inadequate surface support to withstand the K45 360 weight**
- **Wind and weather conditions – ice, snow, gusty or strong winds being particularly hazardous to the safe use of the K45 360**
- **All other possible unsafe conditions**

Arrange the angle of the light heads as far as possible to ensure that the light heads are not likely to dazzle people in the near vicinity.

Set the K45 360 up in such a way that it cannot obstruct walkways or areas that form emergency exit routes.

WARNING

The K45 360 can be used indoors or outdoors. Note Recommended Maximum Wind Speed.

Wherever there is any doubt over the wind speed/conditions the K45 360 should be lowered for safety.

Wind speed at 100% height - 45 mph

If using the K45 360 for extended periods, a daily check of the unit is required to prevent against misuse or tampering whilst unattended, and to ensure that the surface is still firm, level and stability is not compromised in any way e.g. waterlogged ground.

Section 6: OPERATING INSTRUCTIONS

Do not use the K45 360 for any purpose other than that for which it is designed – as a mobile floodlighting system.

If more than one operator is expected to set up or use a K45 360 Lighting System at different times, each operator is required to follow all safety rules and instructions in the operators manual. That means every new operator should perform a pre-operation inspection and function tests before using the K45 360.

6a) PRE-OPERATION INSPECTION

Always perform a pre-operation inspection.

The Pre-operation inspection is a visual inspection performed by the operator prior to each use of the K45 360. This inspection is designed to discover if anything is obviously wrong with a unit before the operator tests it prior to use.

A damaged or modified K45 360 must never be used. If any damage is discovered the K45 360 must be removed from service until it has been repaired.

Maintenance and repairs can be executed only by authorised personnel. If any person maintaining or repairing the device is in any doubt they should contact their dealer or Ritelite (Systems) Ltd.

PRE-OPERATION INSPECTION

Check the following parts or areas for any signs of damage or missing parts.

- Leg carriages
- Cables (for kinks, frays, abrasions)
- Plugs
- Legs
- Mast column
- Nuts, bolts and other fasteners
- Lifting points

- Check to make sure that there are not dents, weld cracks in the product or signs of excessive rust.
- If using the optional rough terrain wheel kit, check the tyres are inflated adequately and do not exceed the maximum pressure stated on the tyres.
- Make sure the light head transit lock is fully engaged.
- Make sure that all structural and other critical components are present and all associated fasteners and pins are in place and properly tightened.

Make sure all labels and warnings are present and readable on the product as detailed in section 5 of this manual.

6b) UNIT STABILITY DEPLOYMENT PROCESS



1. Push the K45 360 to a vertical position onto its base on firm, horizontal ground, away from overhead obstacles such as trees or power lines. Position the unit so that all four of the stabilizing legs can be located on firm ground when deployed.

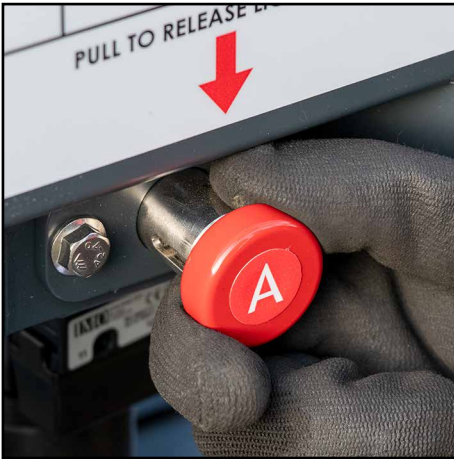

2. Pull out the light head transit lock.



3. Pull out all four leg release catches and lower the legs to the ground.



4. Check the brightness dial is turned fully to the left to the 0% position.



5. Connect the power cable and turn on the main power switch. A leg stability LED should illuminate, indicating that the leg is not adjusted correctly to support the product securely.



6. Rotate the knobs to adjust the leg carriage. The leg should click in so it will not raise when pulled upwards. Then adjust the knob until pressure is applied to the ground, the red LED will extinguish when enough pressure is applied.



7. From the control panel side walk in a clockwise motion around the product starting from the level and secure first leg. Continue to secure all legs. Ensure they can't be pulled up and adjust the knobs until enough pressure is applied and the LED's are all extinguished. Pay attention to the bubble level and adjust the legs so the unit is as straight as possible.

Note the position of the leg tie bar, it should latch in below the leg height adjustment mechanism. If not the leg adjuster knob should be turned clockwise to lift the mechanism up enough so the tie bar now locates below it. This will depend on the ground level and last position the adjuster was set at.



WARNING

It is important that all legs are lowered with locating pins fully secured below the leg carriage with all LED's extinguished before attempting to raise the mast. The unit must be totally stable and level.

6c) FUNCTION TESTS

Before each and every use it is recommended that the following function tests are carried out to make sure that there are no operational issues with the K45 360 before set up continues.

Any K45 360 that is not working properly must not be used and must be removed from service until a full inspection and any necessary repairs have been carried out.

Maintenance and repairs can be executed only by authorised personnel.

If any person maintaining or repairing the device is in any doubt they should contact their dealer or Ritelite (Systems) Ltd.

After repairs are completed, the operator must perform a pre-operation inspection and function tests again before the K45 360 is used.

- Select a test area that is firm, horizontal, level and free from obstructions.

Follow the setting up procedure to stage 7 when the K45 360 is properly stabilised and the legs are all down and locked securely and the light heads are cleared from the transport locks.

Test of compressor operation

1. Raise the light heads by pressing the 'Mast Raise' button. After a few seconds press the 'Mast Stop / Lower' button to stop.
Result – the mast should raise smoothly free from hesitation or any friction.
2. Lower the light heads by pressing the red 'Mast Stop / Lower' button to lower the mast.
Result – the mast should lower smoothly free from hesitation or any friction.

6d) RAISING AND LOWERING MAST PROCESS

RAISING THE MAST



1. Press the 'mast raise' button once to raise the mast until the light heads are above the top of the unit if they aren't already, then press the red 'mast stop' with a quick press to stop.

Note: A longer press of the stop button will lower the mast.



2. Adjust the light heads to the desired positions, they can be rotated from 180° through to 360°. Adjust the downward angle as required.



180° Setup



360° Setup

ROTATING LIGHT HEAD UPGRADE KIT (OPTIONAL)

We offer an option of a K45 model which allows the light heads to be rotated. This is useful when setting up the light heads to point one direction. When the light head is lowered this enables full 360° rotation of the K45 light head without the need to reposition the product.



3. Press the 'Mast Raise' button. The mast will now automatically raise to it's full height. It is normal for the mast to pause for several seconds as the air pressure builds up to raise each mast section.



4. The mast will automatically stop and the compressor will stop when the light heads are fully extended and sufficient air pressure to support the lights is reached. The light heads can also be stopped at any height desired by a quick press of the red 'Mast Stop / Lower' button.

Note: A longer press of the stop button will lower the mast.

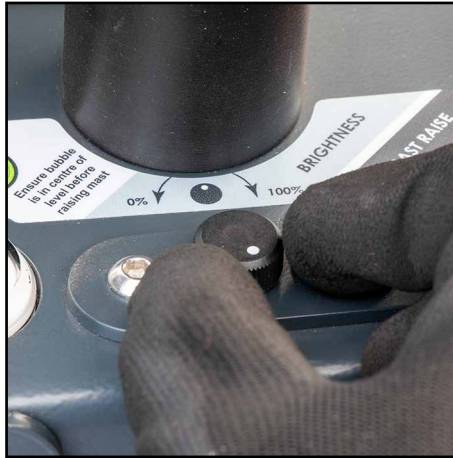

5. Rotate the 'Brightness' dial to the desired light level.

WARNING

As you raise or lower the mast always be conscious of other personnel and the surrounding area above and around the K45 360. No persons other than the K45 360 operator should be in the vicinity of the K45 360 when the system is being set up.

CAUTION

The mast is fully extended when the compressor automatically turns off. The light must NOT be set up in a way that it may form a hazard or nuisance to other persons.

Make sure the K45 360 is stable and no adjustments have been made, or ground firmness has changed whilst the K45 360 has been left unattended.

LOWERING THE MAST

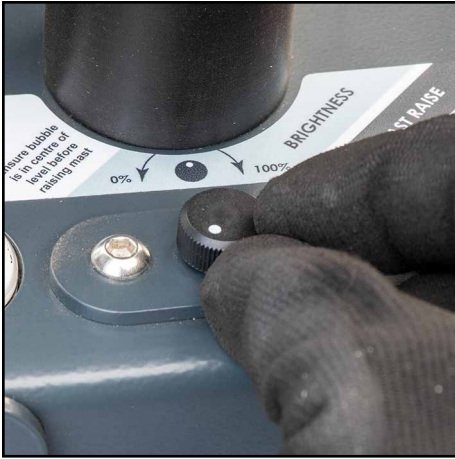

1. Rotate the 'Brightness' dial fully to the left to the 0% position.



2. Press and hold the 'Mast Stop / Lower' button for a couple of seconds to release the air pressure in the mast. The light heads will descend - pay attention at all times as they lower.



3. When the light heads reach the top of the frame they will be held by the gas strut and stop. Fold the light heads back into their stowed position.



4. Push the light heads down into the frame until the transport lock clicks and holds them in position.

WARNING

As you lower the mast always be conscious of other personnel and the surrounding area above and around the K45 360. No persons other than the K45 360 operator should be in the vicinity of the K45 360 when the system is being taken down.



5. Once the light heads are stowed, rotate all of the leg knobs clockwise to release the locking mechanism from the leg tie bars.



6. As each leg is slackened off an LED will illuminate.



7. Pull the red leg carriage lever towards you to release the locking mechanism from the leg carriage. Hold in position and raise the leg.



8. Ensure the leg locks securely into the K45 frame. Repeat with all other legs.



9. Turn off the power and disconnect the cable.



10. Grasp the handles and take the K45 360's weight as you lower it gently onto the wheels for transport. If you are in any doubt enlist the help of others.

6e) PACKING AWAY & TRANSPORT

CAUTION

In slippery or uneven terrain it is recommended that two people manoeuvre the product at all times.

Take extra care handling light heads when packing the K45 360 away for transport in case housings are still hot.

TRANSPORT AND LIFTING INSTRUCTIONS

- The transport vehicle must be parked on a level surface.
- The transport vehicle must be secured to prevent rolling while the K45 360 is being loaded.
- Be sure the vehicle capacity, loading surfaces and chains or straps are sufficient to withstand the K45 360's weight. See the serial plate on the K45 360 for exact weight.
- The K45 360 must be secured to the transport vehicles with chains or straps of ample load capacity.
- Check lifting points are not damaged before lifting product.
- It is recommended that the unit is lifted by 2 persons to avoid injury.

OPTIONAL ROUGH TERRAIN WHEEL KIT



The optional rough terrain wheel kit is a useful accessory which improves the handling and stability on all surfaces. It can be fitted and removed in seconds. It allows for four wheel or two wheel transport to aid manoeuvrability. Notice the counter balance provides easy control of the product.



1. With the K45 standing on its base, place the lower hooks of the wheel kit over the K45 axle.



2. Lift the wheel kit upwards and lock into position with the drop latches.

TRANSPORT ROLLERS

The K45 360 is fitted with a roller on the opposite side to the power sockets to aid loading into a vehicle.

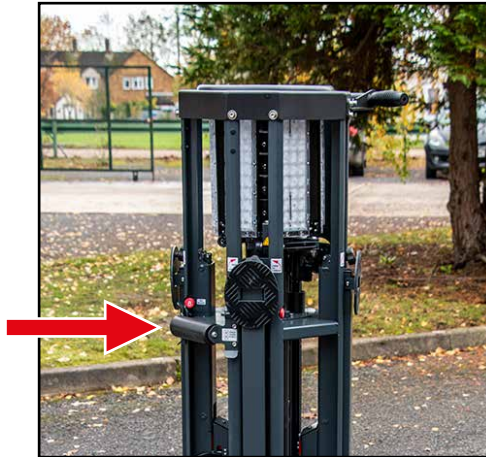

LOADING THE K45 360

Manoeuvre the K45 360 into position next to the vehicle. Tilt the K45 360 so the roller is positioned on the floor at the edge of the load area. Ensure the roller will then move freely to aid loading and there are no obstacles in the way that may stop it moving.

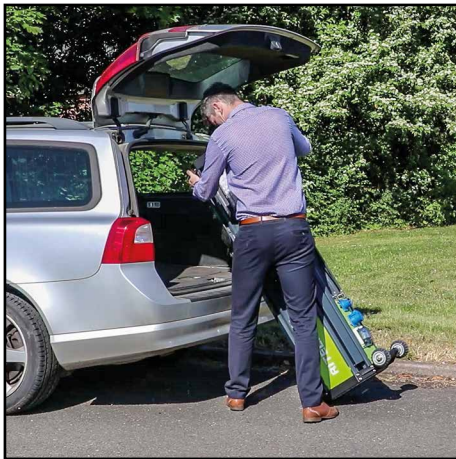

Use correct lifting techniques to load the K45 360 into the transport vehicle by lifting with two people, use the roller as a pivot point to manage the weight and aid loading.

Secure the K45 360 on the transport vehicle using the tie down points. Alternatively secure using a strap around the frame. Do not secure by attaching through the frame as this could damage the internal components.

Section 7: MAINTENANCE

- It is recommended that all K45 360 products are PAT tested at least on an annual basis. Owner / manager to assess and decide frequency of PAT testing required depending on regularity or type of use.
- It is recommended that a regular inspection of the complete product is carried out to look for signs of wear and tear and identify possible maintenance required. This should be done by a competent person on at least an annual basis depending on severity and types of use.
- It is recommended that gloves are worn during cleaning and maintenance to protect the user.
- When removing the light heads (load) during deep maintenance or the removal of parts, ensure the product is laid flat to prevent uncontrolled movement of the mast sections in disassembly.
- Any damaged parts that could pose a risk to the user/personnel must be replaced.
- All sliding and rotating mechanisms must be kept clean and lubricated where applicable.
- The K45 360 must be taken out of service if, during use, or repair and maintenance serious damage is discovered.
- The K45 360 can only be put back into use after it has been properly repaired and examined and signed off by authorised personnel.
- The use of spares other than original parts from Ritelite (Systems) Ltd will invalidate any warranty.
- The mast sections need lubricating by applying 5ml of 0-20W oil to each service hole after 250 operations or 6 months.
- Periodically the mast sections need taking apart so the seals/scrapers can be checked cleaned, re greased and put back together. Request 'Mast service document' from Ritelite to support this process.

ADVICE ON DISPOSAL OF RITELITE PRODUCTS AT END OF LIFE

For our latest advice on the disposal of Ritelite products at end of life please visit the link below.

<https://www.ritelite.co.uk/disposal-advice>

DISCLAIMER OF WARRANTY

For details about the warranty offered on Ritelite products please visit the link below.

<https://www.ritelite.co.uk/warranty-information>

The contents of this manual are subject to change without prior notice.

We take no responsibility for errors or admissions.



Ritelite (Systems) Ltd

Meadow Park, Bourne Road, Essendine, Stamford, Lincolnshire, PE9 4LT

Tel. +44 (0) 1780 758585 E-mail. sales@ritelite.co.uk

www.riteliteportablelighting.co.uk